

High Productivity Cooking Variomix Electric Boiling Pan with Stirrer 200lt, 600mm tilting height

ITEM # _____

MODEL # _____

NAME # _____

SIS # _____

AIA # _____

232226 (SM6V200)

 Electric boiling pan 200lt
 with stirrer, with 600mm
 tilting height

Short Form Specification

Item No.

AISI 304 stainless steel construction; deep drawn pan with rounded edges manufactured from AISI 316 stainless steel. Pan can be tilted beyond 90° to completely empty the food. Motorised tilting with tilting axis located at the front of the pan to keep the pouring lip high and allow tall vessels to be filled. Food is uniformly heated via the base and the side walls of the pan by an indirect heating system using integrally generated saturated steam at a temperature of 120°C in a jacket with an automatic deaeration system. Safety valve avoids overpressure of the steam in the jacket. Safety thermostat protects against low water level. Max pressure at 1,5 bar. Programmable water filling system. Bottom agitator mixes at speeds from 25 to 100 rpm. Whipping cycle up to 200 rpm. Continuous rotating or 2 rotating directions with the possibility to modify times. Step program facilitates removal of food. High thermal input and fast heat up. Electronic SMART control with possibility to store 50 programs; error message facility; display with: cooking time and temperature, water filling. Heavy duty balanced stainless steel lid, easy to remove and turn to facilitate cleaning. The insulation allows a lower temperature on the outer panels. The foamed thermal insulation guarantees a cool upper edge of the cooking vessel surface. IPX5 water protection. For freestanding installation one left column is necessary for each unit. 600mm tilting height.

Main Features

- 600 mm tilting height minimum.
- Food is uniformly heated through the base and side walls of the pan by an indirect heating system which uses integrally generated saturated steam at a temperature of 120°C in a jacket with an automatic deaeration system.
- Fast working thanks to the high efficient heating technology and well insulation that keeps the heat inside the well.
- Electronic control with possibility to store up to 50 programs, large display for easy use and a complete control over the following functions: start, cooking time, temperature, water filling and mixing speed.
- Curved pan base guarantees that the appliance is also suitable to prepare small quantities of food.
- Constructed to meet the highest hygiene standards.
- Compliant to CE requirements for safety.
- Safe thanks to the higher water protection IPX5 and the lower temperature outside the panels.
- Isolated upper well rim avoids risk of harm for the user.
- High thermal input and fast heat up.
- Safety thermostat protects against low water level.
- Safety valve avoids overpressure of the steam in the jacket.
- ACCESSORIES:
 - Whipping tool - quickly whips foods such as cream, egg whites, etc
 - Bottom agitator - blends foods such as meat stews, casseroles, etc
 - Cleaning tool - may be fitted on the rotating shaft
- OPTIONS (to be ordered with the machine and must be installed in the factory):
 - Automatic water filling - makes it possible to preset the desired quantity of water
 - Automatic cooling - allows cooling down of the food

Construction

- Ergonomic and user friendly thanks to the high tilting position and the pouring lip design which allow to easily fill containers.
- Heavy duty, balanced stainless steel lid with sliding plastic cover to insert ingredients. Easy to remove and turn to facilitate cleaning.
- Tilting axis located at the front and upper position of the pan to keep the pouring path short when filling different types of vessels.
- Vessel can be tilted beyond 90° to completely empty the food.
- Motorised tilting.
- Max pressure 1,5 bar.
- AISI 304 stainless steel construction with AISI 316 stainless steel deep drawn pan with rounded edges.
- Variable speed agitator moves at up to 200 rpm.

Sustainability



APPROVAL: _____

- High-quality thermal insulation of the pan saves energy and keeps operating ambient temperature low.

Included Accessories

- 1 of GRID STIRRER W/SCRAPERS FOR 200L PNC 928054

Optional Accessories

- STRAINER 200L PNC 928027
- Kit for easy positioning and installation of 150-300 lt pan (for a correct installation you need 2 for each pan). PNC 928030
- FOUNDATION FRAME LEFT COLUMN PNC 928031
- FOUNDATION FRAME RIGHT COLUME 150-300L PNC 928033
- FASTENING FRAME LEFT COLUMN (FOR BOLTING) PNC 928034
- FASTENING FRAME FOR RIGHT COLUMN 150-300 PNC 928036
- TROLLEY TO STORE TOOLS FOR 5 BOIL. PANS PNC 928043
- TROLLEY TO STORE TOOLS FOR 2 BOIL. PANS PNC 928044
- DISTANCE RING F.CONNECT.(PREV. VERS.PAN) PNC 928049
- SET OF SCRAPERS F.GRID STIRRER 200L PNC 928059
- WHIPPING TOOL FOR 200L PNC 928074
- BRUSH (SHORT) FOR SPRAY UNIT PNC 928082
- BRUSH (LONG) FOR SPRAY UNIT PNC 928083
- Cleaning tool for Variomix boiling pans, 200lt PNC 928122
- Left column including with bearing and cover for boiling pans, with 600mm tilting height PNC 928150
- Cover plate on the right side for 150-300lt pans, with 400mm tilting height PNC 928152
- Dual installation feeding cable for 200 and 300lt boiling pans smart variomix and smart promix with 600 mm tilting height PNC 928160

Front

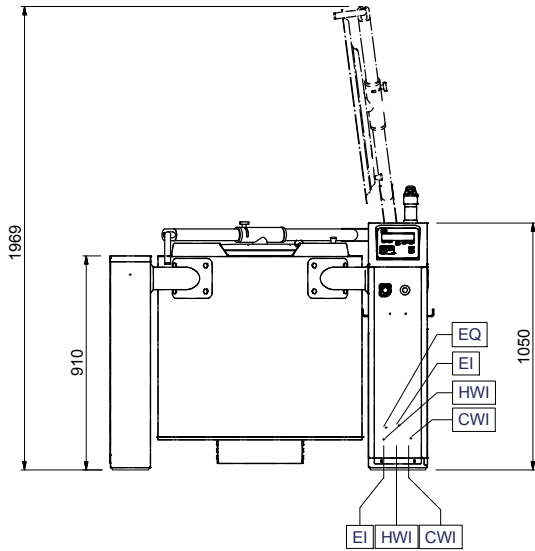

Side

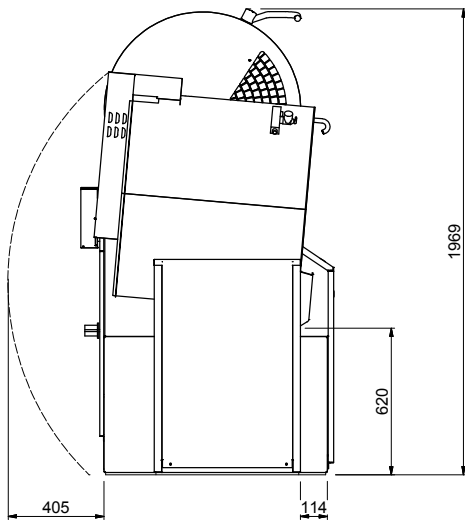

CWI = Cold Water inlet 1 (cleaning)
 EI = Electrical inlet (power)
 HWI = Hot water inlet

Top

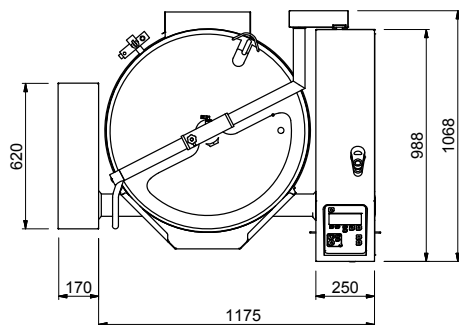

Electric

Supply voltage: 400 V/3N ph/50-60 Hz
 Electrical power max.: 40 kW

Installation:

Distance back floor tilted: 620 mm

Key Information:

Working Temperature MIN: 30 °C
 Working Temperature MAX: 121 °C
 External dimensions, Width: 1345 mm
 External dimensions, Depth: 1070 mm
 External dimensions, Height: 1050 mm
 Net vessel useful capacity: 200 lt
 Tilting mechanism: Automatic
 Bearing: Front